

# Cooling System Principles

## Engine Tune

Engine tune can be one of the greatest factors in water and oil temp. A lean mixture (air fuel) and or retarded timing situation will make heat quickly. Lean mixtures burn hot causing detonation and pre-ignition. Retarded timing makes the engine work hard (labor) to compress the air fuel mixture, then fires well after TDC at a reduced compression ratio. Exhaust valve timing or exhaust restriction will hold heat in the engine raising water temp. These conditions also affect oil temp through cylinder head and pistons.

## The Big Five

With the engine tune problems eliminated it comes down to five major factors;

1. Heat production (BTUs / HP)
2. Radiator Capacity (heat dissipation)
3. Air Flow
4. Water Flow
5. System Pressure

## BTUs

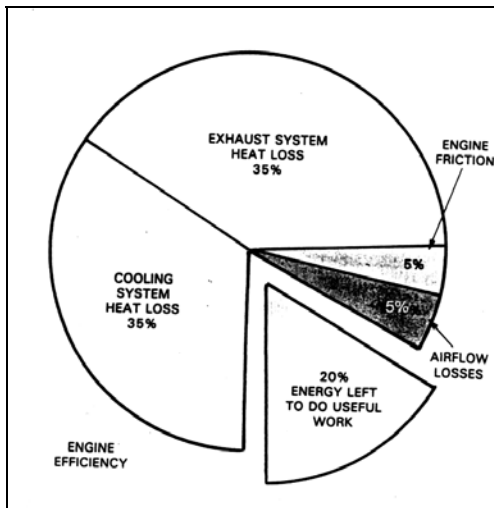

Using a little science and math you can convert your horsepower or fuel consumption to BTUs (heat). For every gallon of gas you burn per minute you release 19,000 Btu one third of that heat goes into the water and must be dissipated by the radiator. When calculating radiator capacity you only need to consider the horsepower your using continuously not the amount your engine is capable of producing. For example a 500-hp stockcar will need much more cooling capacity than an 850-hp dragster. The stockcar will cycle above and below peak horsepower twice a lap heat soaking the cooling system with 855,000 Btu in a ten-minute event. The dragster in one round may idle less than ten minutes and make a 9 second run at a 750 horsepower average. Running 10 seconds at full throttle the dragster would release about 25,000 Btu. In the case of the dragster the system must be adequate enough to prevent detonation under power and maintain temperature at idle.

## Heat Dissipation

Radiator capacity, in this case, refers to the amount of heat it can dissipate not the amount coolant it can hold. Due to the various designs and materials used in radiators today you can not judge them on size alone. In the passed all radiators were made from copper/brass. Copper was the obvious choice for the cooling fins because of its superior heat dissipation. The problem is the solder used to join the two materials reduces the amount of heat that can be transferred to the copper. In the last ten or fifteen years aluminum has become the material of choice for racing and original equipment radiators. The major design changes have been the switch from  $\frac{1}{2}$  -  $\frac{3}{4}$  inch wide tubes to  $1\frac{1}{4}$  -  $1\frac{1}{2}$  wide tubes and the use of dual pass tanks. The wider tubes have more surface area and therefore more heat dissipation. Dual pass designs force the water to the travel length of the radiator twice increasing the amount of temperature drop capable for a given size. Surface area is king when it comes to radiators, doubling the square inch of your radiator will double the heat dissipation, where as doubling the thickness is less affective. Other factors that play a roll in radiator design would be, fin count per inch, down flow (top/bottom tanks) or cross flow (side tanks) configuration, and inlet / outlet size. Coolants will vary in heat transfer characteristics. Many new coolants and additives are available some may have merit but most are just marketing gimmicks "buyer beware". Water is accepted as the best coolant but a trade-off is usually made with glycol-based products to increase the boiling, lubricate the pump seal, and reduce corrosion. If your sanctioning body does not allow glycol-based coolant because obvious track clean up problems use an anti-corrosion / seal conditioner additive available from any parts store.

## Air Flow

Airflow is the most critical factor in water to air radiated system. Nothing affects the radiator efficiency more than airflow. The speed of a vehicle is normally considered when choosing a radiator. Winston Cup teams use different radiators for different situations: full size radiators for short tracks smaller radiators for super speedways and smaller still for restrictor plate tracks. Maintaining adequate airflow at various speeds is critical and more complex than you might think. Whenever you are dealing with the invisible world of aerodynamics the answers are not always common sense. First the radiator must be supplied with fresh air. If the fan is circulating air from the engine compartment (closed one piece front end with no air box) you've got problems. At **speeds less than 30-MPH** electric fans are most affective because they operate independent of engine rpm, supplying maximum airflow at low vehicle speed when you need in the most. Above 35 MPH (with a good grill opening or air box) fans are not necessary and in most cases more air will pass through an electric fan when turned off. Engine driven fans must be properly shrouded to be affective, this means tightly sealed to the radiator with half the fan blade into the opening of the shroud. The fan should have no more than 1-inch clearance to the shroud (15in. fan /17in. opening). At **higher speeds** it can get tricky. Some stock type engine driven fans can reach **blade stall** at high rpm, this means the fan is spinning so far passed it's designed speed that it becomes a wall stopping any air from passing through it. Continuous duty racecars (stockcar, sports cars, rally, etc.) should have a well-designed **air box** to feed the radiator. The air box needs to be tightly sealed to force all the inducted air through the radiator. The inlet to the air box must face square enough into the wind at a high pressure surface of the vehicle to insure the air is forced in and not passing over the inlet at speed. MPH converted to feet per second can be used to calculate the CFM of a grill opening. The size of grill opening necessary is relative to the speed of the vehicle. Example: a super speedway car at 180 MPH average speed would need less than 1/3 of the grill opening necessary for a dirt car at 60 MPH average speed. The radiator core must have a pressure drop across it. This means if air pressure builds up in the fan shroud or the engine compartment the pressure will equalize and air flow across the radiator can stall. Air must be able to escape the engine compartment and trap doors may be necessary on fan shrouds that cover the entire radiator core to avoid back- pressure.

## Water Flow

Many times this is the last aspect of the cooling system to be addressed. Ironically it is also where the majority of problems lie and where most of our work at Meziere Enterprise is focused. The typical stock water pump has excessive clearance and strait impeller blades, usually open front and back. At low speed this produces little flow and is responsible for cars overheating in traffic. At high speeds this design will cause cavitation and aeration. Circle track racers crutch this high rpm condition with underdrive pulleys only to find the engine overheats under caution laps. In engine driven situations the only remedy is a quality-racing pump with tight clearances and a swept blade closed impeller. Where rules and conditions permit electric water pumps can be a solution with multiple benefits. The constant speed of an electric pump eliminates high and low rpm problems. The bonus is you can run the pump when the engine is shut off. **Never run your engine without the water pump, hot spot can form in the cylinder head before your temp gage begins to register.** Mated with a good electric fan you can easily regulate water temp for consistency and rapidly cool the engine between rounds (5 to 7degrees temperature drop per minute).

## Pump and System Pressure

The most widely known principle is that for every pound of pressure in a closed system the boiling point is increased three degrees. For example a 16-lbs. cap increases your boil-over point to 260 degrees (16x3=48). In most cases your motor will be junk after running above 230 for any length of time. But this pressure will suppress boiling while running and boil-over during heat swell that occurs when the engine is shut off. Getting back to the 230-degree mark, it is at this temperature that the incoming water is unable to control hot spots in the water jacket and steam pockets form. The water is diverted around these steam pockets and then all those really bad things happen; cracks, surface distortion and metal fatigue. The pressure produced by the water pump also controls these hot spots which occur around the combustion chambers and exhaust ports. The same boiling point law is in affect here. Racing pumps can generate pressure in the water jacket in excess of 30 psi, quenching hot spots that cause detonation and pre-ignition

# Components

## Surge Tank

Sometimes referred to as an expansion tank or air separator. This tank is used as a fill point when the top of your radiator is lower than engines water outlet. The bottom of the tank is plumbed to the low-pressure (suction) side of the cooling system (after the radiator core and before the pump impeller). The smaller fittings on the upper portion of the tank are plumbed to the high points on the motor and radiator to remove trapped air and aerated water. This reservoir located high and out of the main flow of water allows air to separate out of the water making your cooling system more efficient.

## Pressure Cap

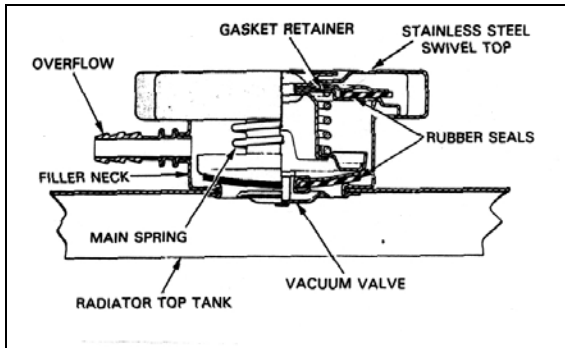

As mentioned previously the more pressure you can hold in a closed system, the higher your boiling point is. So it is in your best interest to run the highest-pressure cap your system can handle. The weakest link is typically the radiator and hoses. The radiator manufacture should be able to suggest the appropriate cap pressure. Check the cap periodically to make sure it is maintaining the advertised pressure. One commonly over looked component is the water neck/filler neck. Most are cast or formed metal. If the pressure caps seat is defective, distorted or poorly designed you can loose water all the motor is running. This situation mimics a bad head gasket, you will notice the engine gets hot faster every round

or hot lap session you run it. You wouldn't be the first or the last person fooled into thinking an engine problem was pushing more and more water out. But the truth is the lack of pressure on the system builds heat faster and the quick boil-over is pushing all the water out.

## Recovery Tank (closed system)

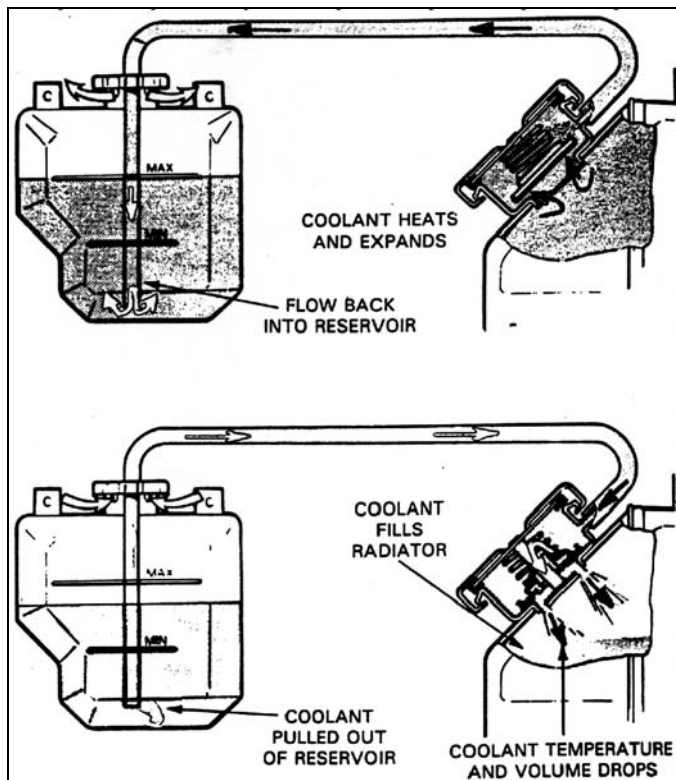

Keeping the system full reduces aeration and allows it build pressure faster. As temperature increases the water expands and pressure builds. If the system is completely full the expansion pressure will exceed the cap pressure and overflow into the recovery tank. If your pressure cap is properly located at the highest point of the system the air will be pushed out first. When the system cools and contracts a vacuum is created. Your radiator cap is equipped with a valve that opens under this negative pressure and will draw coolant back into the system through the tube that extends to the bottom of the recovery tank. Mount the tank as close as possible to the pressure cap allowing the line to be short and level, reducing restriction and the affect of gravity. If the recovery tank is kept half full (with the engine cold) every heat cycle will automatically purge more air out of the system. Potentially, the opposite is true without a recovery system. With every heat cycle water will be pushed out, leaving more air space this air space reduces the system pressure and boiling point.

## Catch Can

What is normally referred to, as a catch can should not be confused with a recovery tank. Most sanctioning bodies require a one-quart or larger catch can to contain water overflow from the cooling system. Its function is to keep coolant off the track and you on the track. It will also give you some idea of how bad your over heating condition is based on how much coolant you drain from it.

## Thermostat

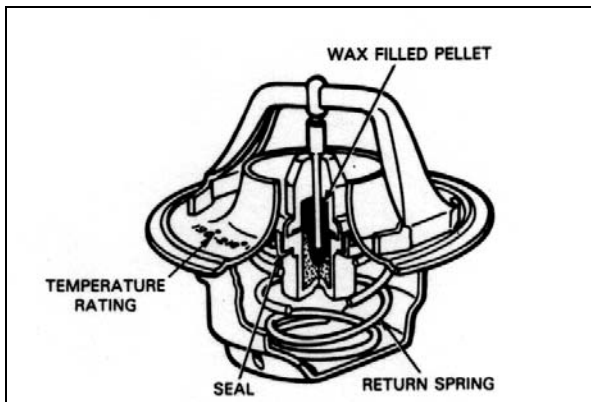

For most applications, with the exception of drag racing, a thermostat is recommended. Most racers avoid thermostats seeing them as another part to fail, but their benefits far outweigh their stigma. A water outlet restrictor can be used in place of the thermostat if you prefer. In our opinion Robertshaw high flow (available from Mr. Gasket, Milidon, or Moroso), Stant Superstat or the highly reliable Cloristat used in Volvo 4 cylinder engines (fits Chevy V8s) are the best choices. The Robertshaw thermostat offers the least amount of restriction when fully open which is desirable for electric pumps incapable of producing high dynamic pressures. The thermostat's main purpose is to bring the engine quickly up to operating temperature and maintain that temperature (see section; Recommended

Operating Temp). The restriction at the water outlet will maintain an even block pressure (reducing localized boiling) during pressure surges produced by mechanical pump rpm cycles. Under deceleration the drop in pressure can allow the coolant to boil and in extreme cases this can occur in the radiator with the related expansion causing the radiators tubes to balloon.

## Recommended Operating Temperatures

There are a few different theories on coolant temperature and most have their place. Cold water (under 170F) and hot oil (230F) make power; this is a proven fact and the rule for drag racing. In most other forms of racing and street applications the engine is under power for minutes or hours rather than a few seconds. In this case higher temperatures in the range of 190 to 210F are necessary for engine components to normalize. Many inherent or design factors determine this temperature; block and head castings, metal properties, proper fuel combustion and machined clearances. Either inherently or by design small block Chevrolet engines prefer 195 to 205F and big block like it a few degrees hotter. Most early domestic V8s are right in that neighborhood. Fuels react to temperatures related to engine temp and combustion pressure. Low octane gasoline burns more completely at higher temperatures, so manufacturers design late model engines to operate above 210F for reduced emissions. Alcohol has a narrow window for proper combustion. Many tuners recommend a water temperature above 195 to avoid fuel washing the cylinders from an incomplete burn and below 205 where the fuel can byproduct can leave harmful deposits. The internal clearances such as piston to wall and ring gap are set for a predetermined operating temp by the engine builder. The chart below illustrates the excessive wear that occurs with coolant temperatures below 170 degrees F.

## New Or Not So New Ideas

Many times what seems to be a new idea is really just borrowing an old one. Theories like reverse cooling or water distribution manifolds and plumbing have been around a long time. The recently departed Smokey Yunick (1923 - 2001) is credited with developing reverse cooling long before GM made it popular with the introduction of the LT-1. The theory is, running the water through the cylinder head first where the critical hot spots are, reduces detonation and also maintains a cooler air intake producing more power. With an engine operated at lower coolant temperatures (such as a drag car) the cylinders benefit from the warmer water flowing down from the heads. Going back even further, some engines were manufactured with distribution manifolds inside the water jacket. The idea here is distributing the cool water evenly throughout the engine. Most engines come from the factory with the water entering and exiting from the front of the engine this causes the front cylinders to run much colder than the rear. External plumbing is used to help balance cylinder temperatures and remove trapped air. The block, head or intake can be tapped to feed water to or draw water out of areas lacking in flow or critical hot spots such as siamese exhaust ports. A more common procedure is to tap the back corners of the intake manifold or back of the head to return water to thermostat housing below the thermostat or restrictor. This promotes water flow to the rear cylinders and helps to remove trapped air.